

High security 16-bit smart card microcontroller



AE470

Features

144kbytes EEPROM; 288kbytes ROM; 8kbytes RAM.

Applications

The highly integrated memory of the AE470 enables it to support multi application cards based on sophisticated Operating Systems (OS), including JavaCard™. It also allows for enhanced functionality of Mobile Communication cards and the implementation of advanced Value Added Services (VAS) to end users. These could include services such as stock exchange information, weather forecasts, online gaming and reservations for travel or theatre.

The AE470 is manufactured in specially controlled and ISO certified silicon factories located in Germany and Japan using a highly reliable 0.150 µm CMOS process technology allowing much higher integration of memory into a smart card, which is particularly useful for USIM 3G cards with their stronger requirements for data and application storage. The AE470 supports the A, B and C voltage classes (1.8V to 5V) of the current release of specification for mobile communication ETSI-SCP.

Integrated Security Concept (ICS)

The AE470 designed under Renesas Technology's ISC is ideally suited for high security applications. The ISC means that security has been built in right from the start forming an integral part of the whole Smart Card design concept and is not just an add-on feature to standard modules or cores. The whole ISC process (secure chip design environment, secured production facilities and secure handling during shipment to the customer) is constantly reviewed in order to maximise the overall security package. Many security features such as integrated sensors, distributed layout, Random Number Generator (RNG), DES Engine and power analysis attack protection are all included providing a strong on-chip hardware security structure. Uniquely, Renesas Technology Smart Card devices are fabricated using Metal Oxide Nitride Oxide Silicon (MONOS) EEPROM structure. MONOS advantages compared to standard EEPROM structures are high resistance to radiation disturbance, high reliability and endurance.

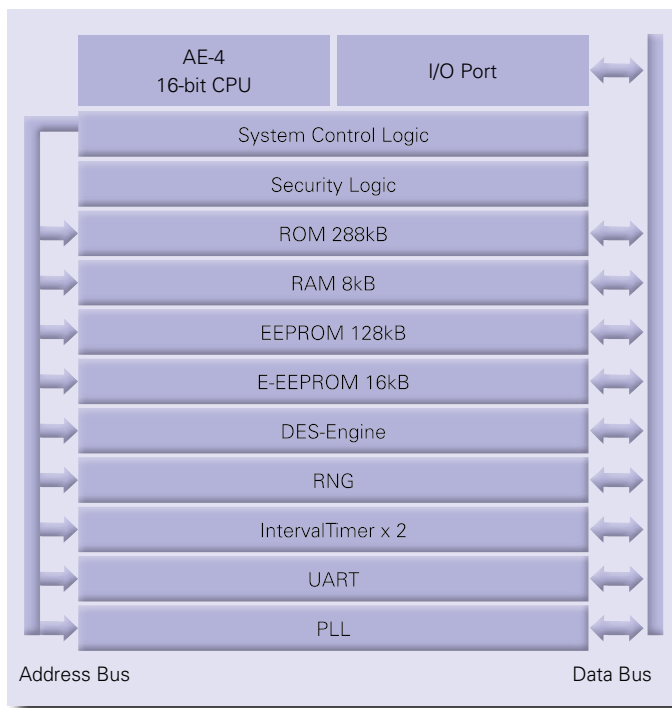

Specification

Item	Specification
Process	0.15µm CMOS process
CPU	AE-4 High performance 16-bit CPU 16 Mbytes Linear Address Space
Minimum Instruction Timing	0.25µs for 32-bit addition 1.75µs for 16 x 16-bit multiplication
EEPROM	FS-MONOS EEPROM process 144kB (including 16kB extra EEPROM) Easy EEPROM write by single instruction Read, write and erase of EEPROM by page 1 to 128 Bytes programming with one instruction Data retention minimum 10 years guaranteed over full operating temperature range EEPROM programming voltage generated on-chip Endurance: greater than 500,000 times Overwrite time: 1ms max Erase time: 1.2ms max Write time: 2.2ms max
ROM	288kB
RAM	8kB
Peripherals	Security sensors DES-Engine, minimum execution time is 18 clock cycles RNG (Random Number Generator) UART PLL 2 x 16-bit interval timers
Power	Single voltage power supply 4.5V to 5.5V 2.7V to 3.3V 1.62V to 1.98V
Clock Frequency Range	External clock input: fclk = 1MHz to 10MHz (Vcc = 4.5V to 5.5V) fclk = 1MHz to 5MHz (Vcc = 2.7V to 3.3V) fclk = 1MHz to 5MHz (Vcc = 1.62V to 1.98V) Internal clock application can select external clock frequency, double or half external clock frequency as internal operation frequency.
Operating temperature range	-25 to + 85°C (storage temperature)

