

High-security 16-bit microcontroller



RS-4 family

RS-4-You



RS-4

The RS-4 is a 16-bit high-security microcontroller designed for high-performance and multifunction smart cards based on sophisticated Operating Systems (OS). It offers enhanced performance comparable to conventional 32-bit secure microcontrollers and five times faster than Renesas' conventional 16-bit secure microcontrollers. This high performance, together with the integrated encryption processing functions, makes the RS-4 well suited for all different types of high-security applications, such as those in the financial and identification fields. The dual-interface products of the RS-4 family support both contact (ISO7816) and contactless (ISO14443) communication interfaces.

The contactless interface is designed for type A, type B and FeliCa™ communication.

Special features, like internal frequency adjustment, together with low-power design methodologies, ensure optimised functionality for portable devices.

The RS-4 family is upwardly compatible with our existing AE-4 secure microcontrollers and its features and support tools are designed to make the implementation of a secure system easier for the software developer.

RS-4 dual-interface secure MCU features

CPU	Memory	Crypto Coprocessors	Peripherals	Security functions	Interface
<ul style="list-style-type: none"> • 16-bit RS-4 core • Up to 20MHz internal clock • 16 x 16-bit general purpose registers • 16MB linear address space • High performance, low-power • One clock cycle per instruction 	Up to <ul style="list-style-type: none"> • 144kB EEPROM • 288kB ROM • 6.5+2kB RAM 	<ul style="list-style-type: none"> • Modular multiplication <ul style="list-style-type: none"> – RSA 2624-bit, – Up to 40MHz clock • Triple DES • CRC • AES 	<ul style="list-style-type: none"> • Internal oscillator • UART (supports 8 clk/etu) • Interval timers 	<ul style="list-style-type: none"> • Detectors for voltage, frequency, others • True Random Number Generator (AIS31 class P2) • Watchdog timer • On-chip memory check • Fault-tolerant design 	<ul style="list-style-type: none"> • CONTACT • ISO/IEC 7816-3 • CONTACTLESS ISO/IEC14443 TYPE A, B AND FELICA™ • I/O2

RS47X block diagram

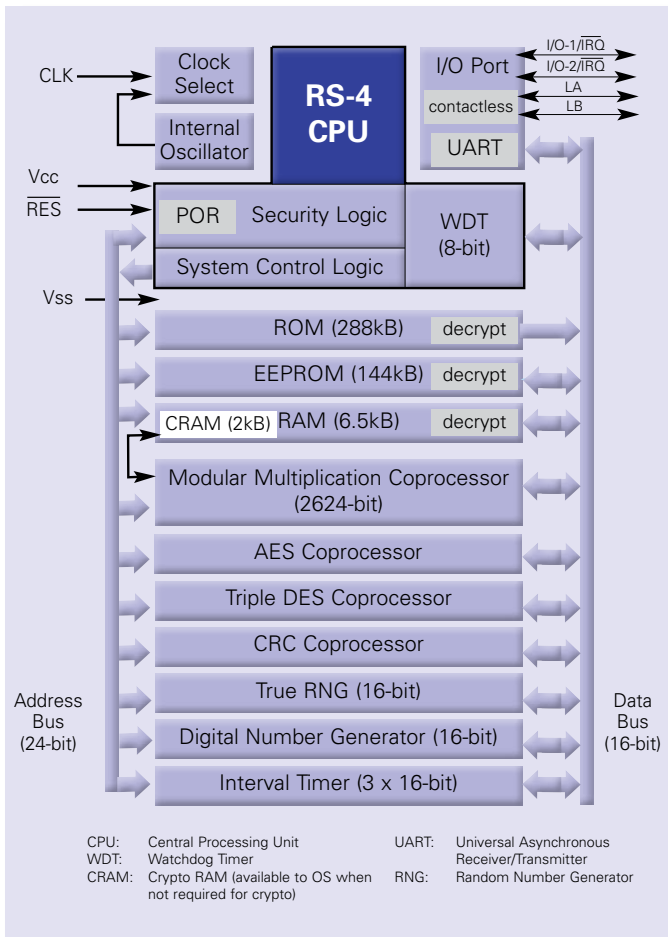

RS-4 highlights

Strong security

- Based on proven AE-4 & AE-5 platforms
- Enhanced features
- Fault-resistant technology

State-of-the-art cryptography

- RSA up to 2624-bit
- AES coprocessor
- Triple DES coprocessor
- CRC coprocessor

Outstanding performance

- Low-power design
- Optimised computing power
- Superior contactless interface
- Code compatible with AE-4 & AE-5

Superior technology

- Family concept
- Reliable FS-MONOS NVM memory
- Roadmap from 150nm to 90nm
- High performance development tools

Variant	Standard (Contact)		Dual-Interface products			
	RS44C	RS45C	RS44X	RS45X	RS46X	RS47X
EEPROM	18kB	36kB	18kB	36kB	72kB	144kB
Page size	64B	64B	64B			
ROM	192kB	224kB	224kB		288kB	
RAM	4k + 2kB	6k + 2kB	6k+2k+512kB			
Int-Oscillator	Yes		Yes			
UART	Yes		Yes			
TMR	3 x 16-bit		3 x 16-bit			
WDT	Yes		Yes			
HW RNG	Yes		Yes			
CRC	Yes		Yes			
3DES	Yes		Yes			
AES	No		Yes			
RSA	2624-bit		2624-bit			
Contactless interface	N/A		Type B, FeliCa™		Type A, Type B, FeliCa™	
Certification	EMVCo CC		EMVCo CC			

